

RAINWATER

An effective rainwater management system is an important part of every building. Our extensive range of fascia and gutter systems have a profile to aesthetically compliment every roof.



www.roofing.co.nz



Nelson | 03 544 3108



Wellington | 04 566 1971



Blenheim | 03 578 8793



Ashburton | 03 307 0593



Timaru | 03 688 7224



Dunedin | 03 488 2881



Queenstown | 03 442 3883



Wanaka | 03 443 1250



Labour Efficient

Quick to install, snap-on gutter brackets allow easy adjustment of gutter fall.



Long Run

Custom manufactured to length, avoiding the need for joins in most applications.



Pitch

Suitable for pitch roofs with flat soffits and roofs of up to 30° pitch with sloping soffits.



Colour Choice

A wide range of standard colours is available with additional colours and coatings available on request.

MATERIALS & DURABILITY

Available in:

	Thickness (BMT)
Colorsteel®	.55mm G300
Zincalume®	.55mm G300
Galvsteel™	.55mm G300

Gutters also available in copper and aluminium.

Also available in other non-ferrous metals.

Various types of coatings are available to suit all environments including industrial and coastal conditions.

For optimum performance, the severity of the environment in which the cladding will be installed should determine both the metal and type of coating to be used.

MAINTENANCE

To Prevent the accumulation of dirt or other material not removed by rain, manual washing is required.

Recommended washing frequency based on environment:

*Areas that do not receive adequate rain washing e.g. underside of gutters and fascias.

	Environmental conditions	
	Severe	Moderate
Sheltered Areas*	Every 3 months	Every 6 months

All gutters must be kept clean of debris.

With the first sign of surface corrosion the affected are should be cleaned, spot primed and repainted.

Fading will occur over time. Periodic over-painting will be necessary to retain aesthetic value.

Minor white corrosion, which may appear on the underside of fascia and gutters, is a natural weathering phenomenon of pre-painted steel and does not constitute a failure of the coating system.

WARRANTY

Gutters & Fascias are covered by warranty for:

- Coating performance
- Corrosion resistance
- Substrate integrity

Warranty is subject to the use of the appropriate product for the environment.

A written warranty is available on request.

QUAD

Quad's gently curved front and strong swaging offer a unique blend of traditional & modern looks.

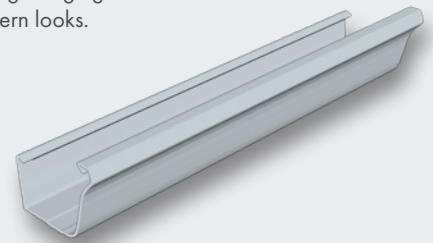
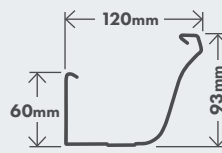

CLASSIC

Our Classic spouting product provides a traditional style spouting suitable for traditional villas and older style homes.

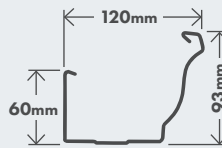

SQUARE

Square spouting (also know as box guttering) has a modern aesthetic and a larger flow load capacity.

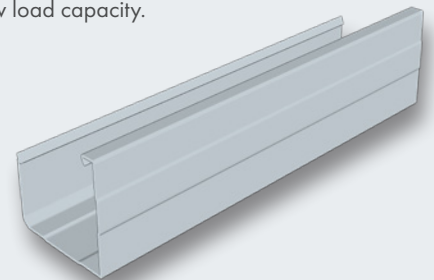
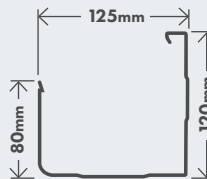

COMMERCIAL

Available in standard sizes, Commercial spouting can be custom-made to fit your commercial/industrial premises.

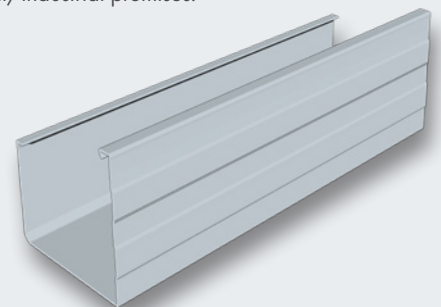
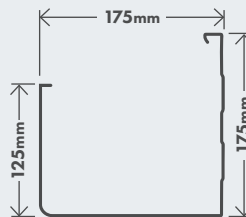

FASCIA

Fascia is used as a base to attach the gutters to or to hide the fixing space between the roof, eaves & wall.

